



NTH 3000-PH30

Neotech Technology

Acid condensate neutralizer with pump

Into the box



Neutralizer
mm 480 x 300 x H 320



Neutralizer granular refill
Neutralkit



A control unit activates the pump through probes. An external system signals the station status and through this system allows manual tests on the working pump.

Max 1200 kW

The neutralizer station of acid condensate with the pump is easy to be installed and allows the evacuation of condensate when it is not possible to discharge by gravity. The strong structure of the tank and the pump NTH3000 make this product reliable. The recharge and the maintenance are easy and fast.



Code	Article	Description
SP040PH3000	NTH 3000-PH30	Neutralizer station with pump
SPN0409026	NEUTRALKIT26	Granular Neutralkit

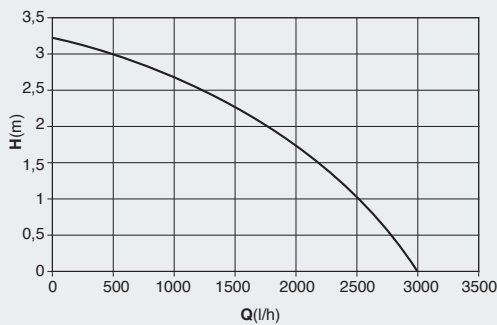

Technical data

- Max generator power 1200kW
- Max flow 120 l/h
- Minimum inlet head..... 130 mm
- Voltage 220V - 50Hz
- Absorption..... 60W
- Max head 3,2 m
- Max flow rate 3.000 l/h
- Dimensions..... 48x30x32cm
- Weight 20 Kg
- Non return valve included 1/2"
- Long-life at max flow..... 1100 h

Ref.	Description
1	Inlet connection G 1"
2	Neutralizer granular refill Neutralkit
3	Inlet filter T Shape
4	Neutralizer box
6	Outlet connection G 1/2"
7	Submerged pump

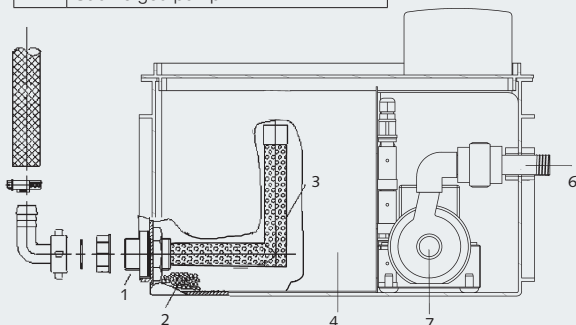

Example of installation

1- wall-mounted or floor standing boilers
The station has to be installed near the boiler and in horizontal position. The inlet pipe to the station will follow the guide lines given by our technical office.

